



MILTECH™ 918

Compact, Portable Military Managed Gigabit Ethernet Switch

FEATURES

One of the most exciting advancement in technology over the last decade has been unmanned vehicles including:

- Unmanned aerial vehicles (UAVs) or Drones
- Land autonomous vehicles (UGVs)
- Robots
- Other unmanned support vehicles

These vehicles must be agile, compact and highly intelligent. In order to support this sophisticated intelligence, these platforms may have to carry and connect a variety of Ethernet-based devices including computers, sensors, and targeting systems - all in compact platforms that must operate in extreme environmental conditions. The MILTECH918 is an ideal Ethernet switching solution for these rugged environments. With the best combination of size, weight, power and cost (SWaP-C) in the industry, it saves valuable real estate and payload.

The MILTECH918 is a MIL-STD, fully managed military grade network switch offering 8 triple-speed (10/100/1000Mbps) ports. It can be remotely managed to optimize communications and prioritize critical information traffic. Advanced network features, never before found in a package of this size, include switching protocols, virtual LANS (VLANs), traffic prioritization (QoS), and bandwidth aggregation are standard.

The MILTECH918's gigabit speeds and 24VDC power make it instantly compatible with any network device and power systems. Its mechanical packaging enhancements, including ruggedized SCE2 circular connectors, is designed for MIL-STD-810F airborne and ground environmental compliance and high reliability. Leveraging best-in-class switching technology from Techaya, the MILTECH 918 serves as a robust commercial off-the-shelf (COTS) solution for rugged LAN connectivity.

SPECIFICATIONS

ETHERNET PORTS	<ul style="list-style-type: none"> • Managed 8 x switched 10/100 /1000 ports
NETWORKING	<ul style="list-style-type: none"> • Spanning Tree (802.1d), RSTP (802.1w) and multiple Spanning Tree (802.1s) for fast recovery rings • Security via Radius Authentication 802.1x, Port Security, Port Mirroring • Multicasting (IGMP Snooping), GARP, GMRP, and GVRP Broadcasting and flooding Control up to 8K Groups. • 802.1q Tagged based VLAN up to 4K VLAN groups. • QoS Multi-Layer Classifier, 802.1p, ToS/DSCP traffic classification. WFQ, Strict Queuing. • Bridge support for Q-in-Q. • L3 static routing • Link Aggregation 802.3AD. • WEB, CLI, Telnet Management. • Rmirror* • Port Protection: 1+1 port protection, 1:1 port protection, 1:N port protection* • G.8032 ring protection* • DHCP option 82 relay* • L2CP tunneling* • Protocol-based VLAN* • 1558v2 PTP with two-step clock* <p>*Available in part numbers 1-918-100, 1-918-101, 1-918-102</p>
CONNECTORS	<ul style="list-style-type: none"> • Power Connector Type: SCE2-B-76A06-075N • LAN Connector Type: SCE2-B-76A07-145N-001 • Management RS-232 Type via Port #1 • LED Indication Per Port (Link/Activity)





MILTECH™ 918

Compact, Portable Military Managed Gigabit Ethernet Switch

SPECIFICATIONS

CHASSIS	<ul style="list-style-type: none"> Machined rugged aluminum Conductively cooled w/custom internal heat-sinks Ingress protection against sand, dust and moisture Anodize Coating, MIL-A-8625, Type II, Class 2
STANDARDS	<ul style="list-style-type: none"> MIL-STD-461E, MIL-STD-810F GM, IP68, MILSTD-1275, MILSTD-704
PERFORMANCE	<ul style="list-style-type: none"> 26.8 Mpps wire speed forwarding rate 20 Gbps maximum forwarding bandwidth 8K MAC Address
STANDARDS COMPLIANCE	<ul style="list-style-type: none"> IEEE 802.1x MAC based Authentication IEEE 802.1Q Vlan Tagging IEEE 802.1P QoS IEEE 802.1S Multiple STP IEEE 802.1W Rapid STP IEEE 802.1AD Link Aggregation IEEE 802.1X
POWER	<ul style="list-style-type: none"> Voltage Input: 24Vdc Nominal (16-36V) Power Consumption: 8W Max Chassis grounding MILSTD-1275 , MILSTD-704
ELECTROMAGNETIC	<ul style="list-style-type: none"> MIL-STD-461E Electromagnetic compatibility CE-102, CS-114, CS-115, CS-116, RE-102, RS-103
ENVIRONMENTAL	<ul style="list-style-type: none"> MILSTD-810F/G/GM: Random vibration (514.5I), Bench Handling (516.6VI), High Temp.(501.5I,II), Low Temp.(502.5I), Humidity (507.5II), Air Pressure (500.5I,II), Blowing Rain (506.5I), Immersion (512.5I), Salt Atmosphere (509.5I), Blowing Dust (510.5I), Loose Cargo Vibration (514.6II), Wind Analysis. IP68
PHYSICAL	<ul style="list-style-type: none"> Dimensions: 100mm (L) x 89(W) x 36(H), including connectors & hardware Weight: 390g
INSTALLATION	<ul style="list-style-type: none"> Set of four 4-40 threads for mounting to any flat surface.
COOLING	<ul style="list-style-type: none"> No Moving Parts. Passive Cooling.
OPERATING TEMP	<ul style="list-style-type: none"> -45°C to +85°C (-49°F to +185°F) Cold Start-Up
STORAGE TEMP	<ul style="list-style-type: none"> -45°C to +85°C (-49°F to +185°F)



MILTECH™ 918

Compact, Portable Military Managed Gigabit Ethernet Switch

A

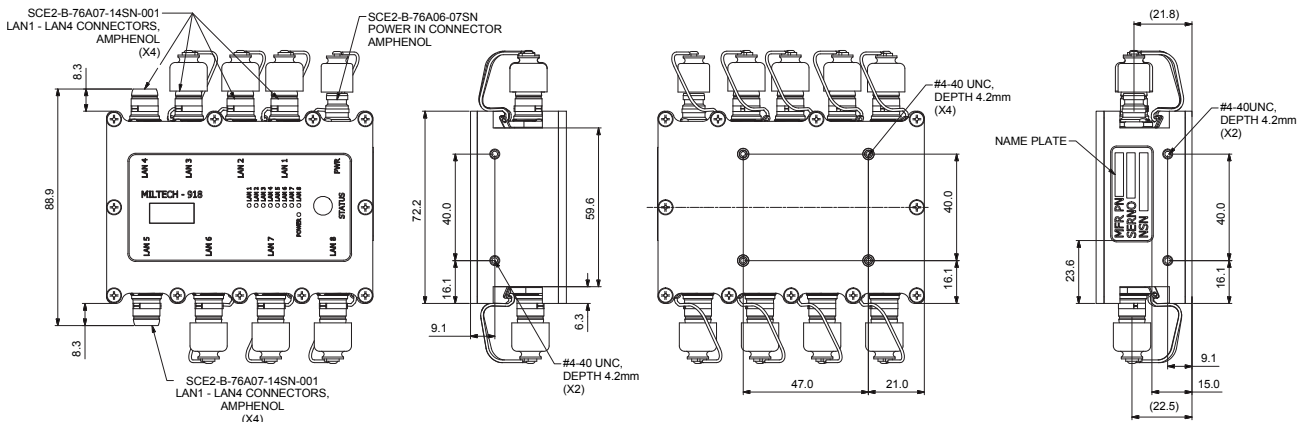

B

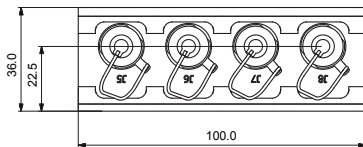

ORDERING INFORMATION

PART NUMBER	DESCRIPTION
1-918-000	Managed Military Gigabit Switch 8 x 10/100/1000TX 16Vdc ~ 36Vdc
1-918-001	Managed Military Gigabit Switch 8 x 10/100/1000TX 16Vdc ~ 36Vdc Dual Power Input
1-918-002	Managed Military Gigabit Switch 8 x 10/100/1000TX 12Vdc ~ 36Vdc
1-918-100	Enhanced Managed Military Gigabit Switch 8 x 10/100/1000TX 16Vdc ~ 36Vdc
1-918-101	Enhanced Managed Military Gigabit Switch 8 x 10/100/1000TX 16Vdc ~ 36Vdc Dual Power Input
1-918-102	Enhanced Managed Military Gigabit Switch 8 x 10/100/1000TX 12Vdc ~ 36Vdc
2-CBL918PWR3M	Power Harness M918 Length 3M
2-CBL9028LAN	LAN Harness for MILTECH9028/9012/918/904 Length 3M
2-CBL9028LN+	LAN & management Harness for MILTECH9028/9012/918/904 Length 3M